



# UniTrane™ W-Line

## High wall fan coil

Model WFS (AC fan motor)

Model WFE (EC fan motor)





## Table of contents

Introduction	3
Mechanical specifications	4
Model descriptions	5
Dimensions and weights	6
General data	8
Performance data	9
Electric heater	13
Operating limits	14
Accessories	15
Controls	16
IR and MB versions	19

# Introduction

W-Line is Trane's high wall fan coil unit range designed and manufactured according to Trane quality standards, in 4 sizes and many different configurations.

It is easy to install, like a standard fan coil. Without decreasing capacity and without any extra frame, 2-way or 3-way valves and condensate pump can be mounted into the casing.

The modern and appealing design of the unit in RAL 9003 colour allows the use of W-Line in any environment. It is available with standard AC fan motors or low energy consumption EC fan motors and in the following versions: with wired wall control, infra-red remote control, MB electronic board for Modbus management and electric heating coil.

The units are for 2-pipe installations only.

All the WFS models perform very low electric consumption and extremely quite sound levels according to the request of today's new projects.





## Mechanical specifications WFS/WFE

### Casing

Made of auto-extinguishing high quality ABS UL94 HB plastic and great resistance to aging. The diffusion flap is adjusted manually in WFS/WFE version, with remote control in WFS-IR/WFE-IR version and with IR-MB control in WFS-MB/WFE-MB version.

### Air filter

Washable synthetic filter, readily accessible.

### Fan assembly

Tangential fan with plastic casing.

WFS models : AC fan technology

WFE models : Variable speed (EC) fan technology

### Electronic motor

Electronic motor with three phase permanent magnet brushless electronic motor that is controlled with reconstructed current according to a BLAC sinusoidal wave. The inverter board that controls the motor operation is powered by 230 Volt, single-phase and, with a switching system, it generates a three-phase frequency modulated, wave form power supply. The electric power supply required for the machine is therefore single-phase with voltage of 230-240V and frequency of 50-60Hz.

### Heat exchanger

It is manufactured from drawn copper tube and the aluminium fins are mechanically bonded onto the tube by an expansion process. The coil has two 1/2 inch BSP internal connections and 1/8 inch BSP air vent and drain.

The heat exchanger is not suitable for use in corrosive atmosphere or in environments where aluminium may be subject to corrosion.

The connections are on the left side facing the unit only.

### Condensate drain pan

Made from polypropylene; the outside diameter of the condensate discharge pipe is 16mm.

### Packaging

A cardboard installation template is supplied with every unit to help the mounting on the wall.

# Model descriptions

## WFS without electric heater

<b>WFS</b>	without infra-red remote control and without valve
<b>WFS-2V</b>	without infra-red remote control with fitted 2 way valve
<b>WFS-3V</b>	without infra-red remote control with fitted 3 way valve

---

<b>WFS-T</b>	with infra-red remote control and without valve
<b>WFS-T-2V</b>	with infra-red remote control with fitted 2 way valve
<b>WFS-T-3V</b>	with infra-red remote control with fitted 3 way valve

---

<b>WFS-MB</b>	with MB electronic board and without valve
<b>WFS-MB-2V</b>	with MB electronic board with fitted 2 way valve
<b>WFS-MB-3V</b>	with MB electronic board with fitted 3 way valve

## WFS with electric heater

<b>WFS-E</b>	without infra-red remote control and without valve
<b>WFS-E-2V</b>	without infra-red remote control with fitted 2 way valve
<b>WFS-E-3V</b>	without infra-red remote control with fitted 3 way valve

---

<b>WFS-IR-E</b>	with infra-red remote control and without valve
<b>WFS-IR-E-2V</b>	with infra-red remote control with fitted 2 way valve
<b>WFS-IR-E-3V</b>	with infra-red remote control with fitted 3 way valve

---

<b>WFS-MB-E</b>	with MB electronic board and without valve
<b>WFS-MB-E-2V</b>	with MB electronic board with fitted 2 way valve
<b>WFS-MB-E-3V</b>	with MB electronic board with fitted 3 way valve

## WFS without electric heater

<b>WFS-E</b>	without infra-red remote control and without valve
<b>WFS-E-2V</b>	without infra-red remote control with fitted 2 way valve
<b>WFS-E-3V</b>	without infra-red remote control with fitted 3 way valve

---

<b>WFS-IR-E</b>	with infra-red remote control and without valve
<b>WFS-IR-E-2V</b>	with infra-red remote control with fitted 2 way valve
<b>WFS-IR-E-3V</b>	with infra-red remote control with fitted 3 way valve

---

<b>WFS-MB-E</b>	with MB electronic board and without valve
<b>WFS-MB-E-2V</b>	with MB electronic board with fitted 2 way valve
<b>WFS-MB-E-3V</b>	with MB electronic board with fitted 3 way valve

## WFE without electric heater

<b>WFE</b>	without infra-red remote control and without valve
<b>WFE-2V</b>	without infra-red remote control with fitted 2 way valve
<b>WFE-3V</b>	without infra-red remote control with fitted 3 way valve

---

<b>WFE-IR</b>	with infra-red remote control and without valve
<b>WFE-IR-2V</b>	with infra-red remote control with fitted 2 way valve
<b>WFE-IR-3V</b>	with infra-red remote control with fitted 3 way valve

---

<b>WFE-MB</b>	with MB electronic board and without valve
<b>WFE-MB-2V</b>	with MB electronic board with fitted 2 way valve
<b>WFE-MB-3V</b>	with MB electronic board with fitted 3 way valve



# Dimensions and weights

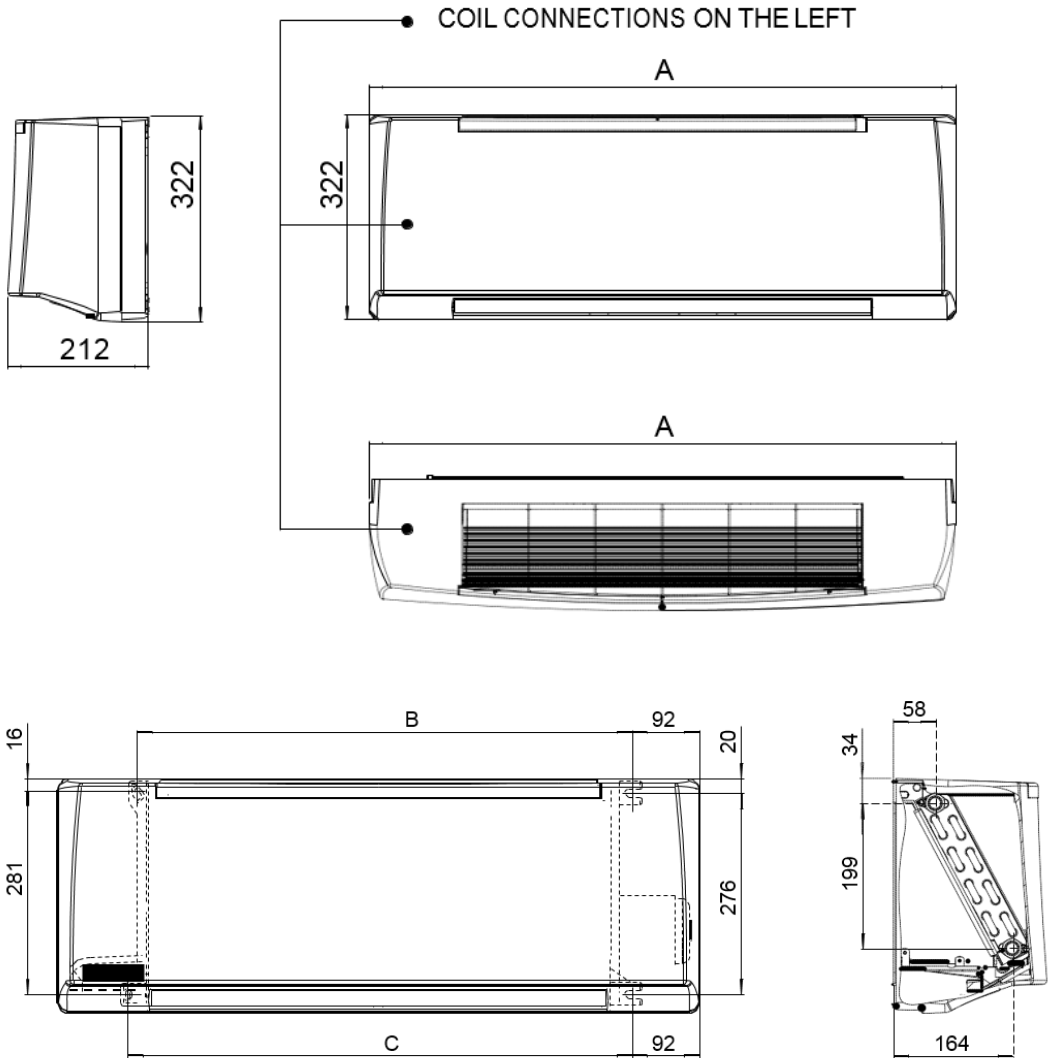

(mm)	WFS/WFE 1	WFS/WFE 2	WFS/WFE 3	WFS/WFE 4
A	880	880	1185	1185
B	678	678	983	983
C	691	691	996	996

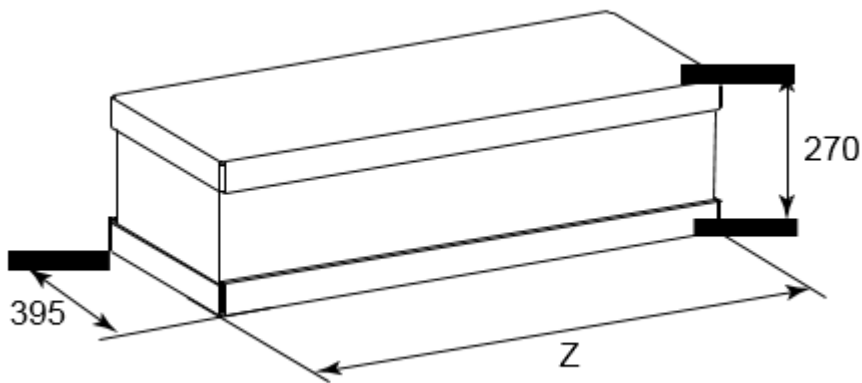

(mm)	WFS/WFE 1	WFS/WFE 2	WFS/WFE 3	WFS/WFE 4
Z	950	950	1255	1255

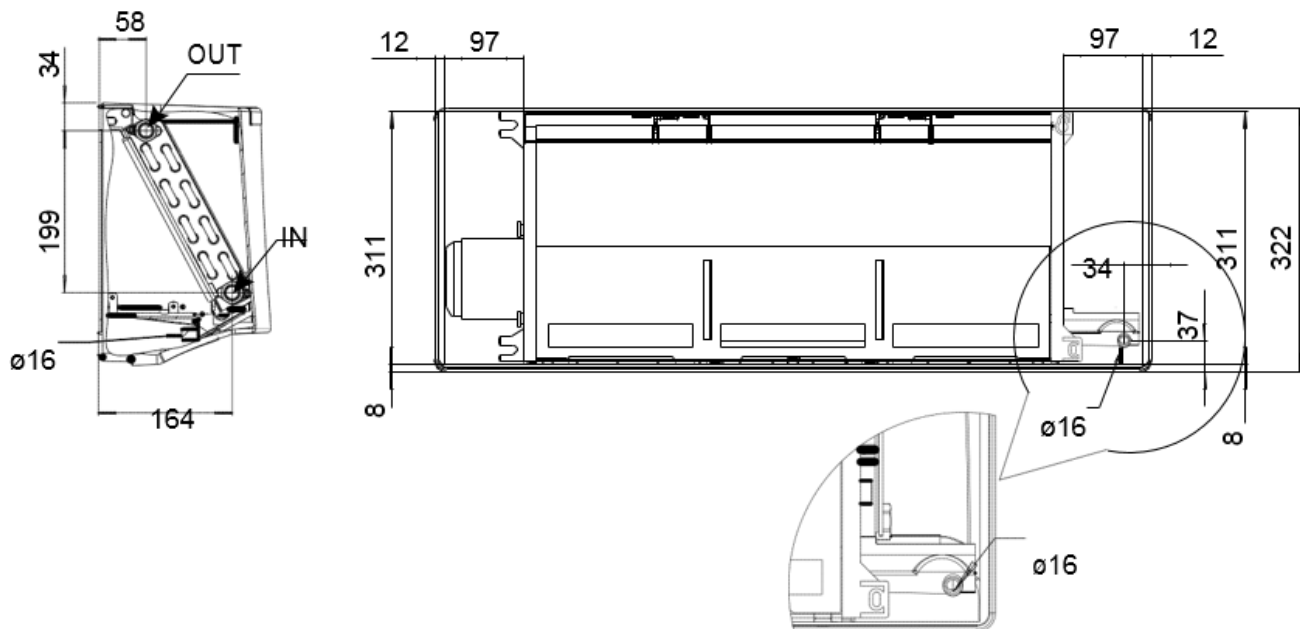

### Weights

	Packed unit (kg)				Unpacked unit (kg)			
	WFS/WFE 1	WFS/WFE 2	WFS/WFE 3	WFS/WFE 4	WFS/WFE 1	WFS/WFE 2	WFS/WFE 3	WFS/WFE 4
Without valve	12	12	16	16	10	10	13	13
With valve	13	13	17	17	11	11	14	14



# General data

## Water content

(l)	WFS/WFE 1	WFS/WFE 2	WFS/WFE 3	WFS/WFE 4
Water content	0,85	0,85	1,28	1,28

## Operating map WFS/WFE

Max. entering water temperature	70°C
MIn. entering water temperature	6°C *
Max. rated pressure	1000 kPa (10 bars)

\*For temperatures below 6°C, contact your local sales office

## Installation height

Model	WFS/WFE 1 - 4
Minimum	2 m
Maximum	3 m

## Motor electrical data (maximum absorption)

Model		WFS 1	WFS 2	WFS 3	WFS 4
230V/1Ph/50Hz	W	30	32	46	48
	A	0,16	0,16	0,23	0,23

Model		WFE 1	WFE 2	WFE 3	WFE 4
230V/1Ph/50Hz	W	15	21	20	30
	A	0,14	0,19	0,18	0,26



# Performance data - Cooling

The following standard rating conditions are used:

COOLING (summer operation)

Entering air temperature: + 27°C d.b. / + 19°C w.b. - Water temperature: + 7°C E.W.T. / + 12°C L.W.T.

## Correction factors for different relative humidities

R.H.	WT:	7/12°C	8/13°C	10/15°C	12/17°C
48%	Pc	0.95	0.94	1.00	1.00
	Ps	1.00	1.00	1.00	1.00
46%	Pc	0.90	0.88	1.00	1.00
	Ps	1.00	1.00	1.00	1.00

## Entering air temperature: +27°C - Relative Humidity: 50%

Model	Fan Speed	Qv m³/h	WT: 7/12 °C					WT: 8/13 °C					WT: 10/15 °C					WT: 12/17 °C				
			Pc	Ps	Qw	Dp(c)	Pc	Ps	Qw	Dp(c)	Pc	Ps	Qw	Dp(c)	Pc	Ps	Qw	Dp(c)				
			kW	kW	l/h	kPa	kW	kW	l/h	kPa	kW	kW	l/h	kPa	kW	kW	l/h	kPa				
WFS 1	6	500	2,40	1,76	413	15,8	2,15	1,68	370	12,9	1,69	1,59	291	8,3	1,31	1,31	224	5,2				
	5	470	2,32	1,69	399	14,8	2,08	1,61	357	12,1	1,63	1,51	281	7,8	1,25	1,25	216	4,8				
	4	MAX	375	2,02	1,44	347	11,6	1,81	1,36	311	9,5	1,41	1,27	243	6,0	1,08	1,08	185	3,6			
	3		340	1,89	1,34	326	10,3	1,70	1,27	292	8,4	1,32	1,17	228	5,3	1,00	1,00	173	3,2			
	2	MED	270	1,62	1,13	279	7,8	1,46	1,06	250	6,4	1,13	0,97	194	4,0	0,85	0,85	146	2,4			
	1	MIN	205	1,33	0,91	229	5,5	1,20	0,86	207	4,5	0,93	0,78	160	2,8	0,70	0,70	120	1,7			
WFS 2	6	545	2,53	1,86	434	17,3	2,26	1,79	390	14,2	1,78	1,70	307	9,1	1,38	1,38	237	5,7				
	5	MAX	480	2,35	1,71	404	15,2	2,10	1,63	361	12,4	1,65	1,54	284	7,9	1,27	1,27	219	4,9			
	4		400	2,10	1,51	362	12,5	1,88	1,43	324	10,2	1,47	1,33	253	6,5	1,13	1,13	194	3,9			
	3	MED	365	1,98	1,41	341	11,2	1,78	1,34	306	9,1	1,39	1,24	239	5,8	1,06	1,06	182	3,5			
	2		305	1,76	1,24	303	9,0	1,58	1,17	272	7,4	1,23	1,07	211	4,7	0,93	0,93	160	2,8			
	1	MIN	250	1,54	1,06	264	7,1	1,38	1,00	238	5,8	1,07	0,91	184	3,6	0,80	0,80	138	2,2			
WFS 3	6	780	4,06	2,91	698	44,5	3,66	2,75	629	36,6	2,88	2,58	495	23,6	2,21	2,21	381	14,6				
	5	730	3,90	2,78	671	41,4	3,51	2,63	604	34,1	2,76	2,45	475	21,9	2,12	2,12	365	13,5				
	4	MAX	545	3,24	2,25	558	29,7	2,93	2,13	504	24,6	2,29	1,95	393	15,6	1,74	1,74	299	9,4			
	3		480	2,97	2,05	512	25,4	2,69	1,93	463	21,1	2,10	1,76	360	13,3	1,59	1,59	273	8,0			
	2	MED	375	2,48	1,68	427	18,3	2,24	1,58	386	15,2	1,75	1,42	300	9,6	1,31	1,29	225	5,7			
	1	MIN	280	2,02	1,35	347	12,6	1,83	1,27	315	10,6	1,43	1,13	245	6,7	1,06	1,02	183	3,9			
WFS 4	6	MAX	790	4,09	2,93	704	45,1	3,68	2,78	633	37,2	2,90	2,60	499	23,9	2,23	2,23	384	14,8			
	5		675	3,72	2,63	640	38,0	3,35	2,48	576	31,4	2,63	2,31	452	20,1	2,01	2,01	346	12,3			
	4	MED	610	3,50	2,45	601	34,0	3,15	2,31	542	28,1	2,47	2,13	424	17,9	1,88	1,88	324	10,9			
	3		500	3,06	2,12	527	26,8	2,77	1,99	476	22,2	2,16	1,82	371	14,1	1,63	1,63	281	8,4			
	2	MIN	440	2,80	1,92	482	22,8	2,53	1,81	436	18,9	1,98	1,64	340	12,0	1,49	1,49	256	7,1			
	1		300	2,12	1,43	365	13,9	1,93	1,34	332	11,6	1,50	1,20	258	7,3	1,12	1,08	193	4,3			

## Entering air temperature: +26°C - Relative Humidity: 50%

Model	Fan Speed	Qv m³/h	WT: 7/12 °C					WT: 8/13 °C					WT: 10/15 °C					WT: 12/17 °C				
			Pc	Ps	Qw	Dp(c)	Pc	Ps	Qw	Dp(c)	Pc	Ps	Qw	Dp(c)	Pc	Ps	Qw	Dp(c)				
			kW	kW	l/h	kPa	kW	kW	l/h	kPa	kW	kW	l/h	kPa	kW	kW	l/h	kPa				
WFS 1	6	500	2,14	1,68	368	12,9	1,91	1,63	329	10,4	1,49	1,49	256	6,6	1,14	1,14	196	4,1				
	5	470	2,06	1,61	355	12,0	1,84	1,56	316	9,7	1,43	1,43	246	6,1	1,09	1,09	188	3,8				
	4	MAX	375	1,80	1,37	310	9,4	1,60	1,31	275	7,6	1,24	1,22	213	4,7	0,94	0,94	161	2,8			
	3		340	1,69	1,27	291	8,4	1,50	1,22	258	6,7	1,16	1,13	199	4,2	0,87	0,87	150	2,5			
	2	MED	270	1,45	1,07	249	6,4	1,28	1,02	221	5,1	0,98	0,93	169	3,1	0,74	0,74	127	1,8			
	1	MIN	205	1,19	0,86	205	4,5	1,06	0,82	182	3,6	0,81	0,74	139	2,2	0,60	0,60	103	1,3			
WFS 2	6	545	2,25	1,79	387	14,1	2,01	1,74	345	11,4	1,57	1,57	270	7,3	1,21	1,21	208	4,5				
	5	MAX	480	2,09	1,63	360	12,3	1,86	1,58	320	10,0	1,45	1,45	250	6,3	1,11	1,11	191	3,9			
	4		400	1,88	1,43	323	10,1	1,67	1,38	287	8,2	1,29	1,29	222	5,1	0,98	0,98	169	3,1			
	3	MED	365	1,77	1,34	304	9,1	1,57	1,29	270	7,3	1,21	1,19	209	4,6	0,92	0,92	158	2,7			
	2		305	1,57	1,17	270	7,4	1,39	1,12	240	5,9	1,07	1,03	184	3,6	0,81	0,81	139	2,2			
	1	MIN	250	1,37	1,00	236	5,8	1,22	0,96	209	4,6	0,93	0,87	160	2,8	0,70	0,70	120	1,7			
WFS 3	6	780	3,64	2,76	625	36,5	3,24	2,66	558	29,6	2,53	2,49	435	18,8	1,94	1,94	333	11,5				
	5	730	3,50	2,63	601	34,0	3,12	2,53	536	27,5	2,43	2,36	417	17,4	1,85	1,85	318	10,6				
	4	MAX	545	2,91	2,13	501	24,5	2,59	2,03	446	19,7	2,00	1,87	344	12,3	1,51	1,51	259	7,3			
	3		480	2,67	1,94	460	21,0	2,38	1,84	409	16,9	1,83	1,68	315	10,4	1,37	1,37	236	6,2			
	2	MED	375	2,23	1,59	384	15,1	1,98	1,50	341	12,2	1,52	1,35	261	7,5	1,13	1,13	194	4,4			
	1	MIN	280	1,82	1,27	313	10,5	1,62	1,20	279	8,5	1,24	1,07	213	5,2	0,91	0,91	157	3,0			
WFS 4	6	MAX	790	3,67	2,78	630	37,0	3,27	2,69	562	30,0	2,55	2,52	439	19,1	1,95	1,95	336	11,6			
	5		675	3,34	2,49	574	31,3	2,97	2,39	511	25,2	2,31	2,22	397	15,8	1,75	1,75	302	9,6			
	4	MED	610	3,14	2,32	539	27,9	2,79	2,22	480	22,6	2,16	2,05	372	14,1	1,64	1,64	282	8,5			
	3		500	2,75	2,00	473	22,1	2,44	1,90	420	17,8	1,88	1,74	324	11,0	1,41	1,41	243	6,5			
	2	MIN	440	2,52	1,81	433	18,8	2,24	1,72	385	15,2	1,72	1,56	296	9,3	1,29	1,29	221	5,5			
	1		300	1,91	1,35	329	11,5	1,71	1,27	293	9,3	1,30	1,13	224	5,7	0,96	0,96	166	3,3			



Entering air temperature: +25°C - Relative Humidity: 50%

Model	Fan Speed	WT: 7/12 °C					WT: 8/13 °C				WT: 10/15 °C				WT: 12/17 °C			
		Qv m³/h	Pc kW	Ps kW	Qw l/h	Dp(c) kPa	Pc kW	Ps kW	Qw l/h	Dp(c) kPa	Pc kW	Ps kW	Qw l/h	Dp(c) kPa	Pc kW	Ps kW	Qw l/h	Dp(c) kPa
WFS 1	6	500	1,90	1,63	328	10,4	1,69	1,58	290	8,3	1,31	1,31	225	6,9	1,09	1,09	188	3,7
	5	470	1,83	1,55	315	9,7	1,62	1,50	279	7,8	1,26	1,26	216	6,4	1,03	1,03	177	3,4
	4 MAX	375	1,59	1,31	274	7,6	1,41	1,26	242	6,0	1,08	1,08	186	4,9	0,83	0,83	143	2,3
	3	340	1,49	1,22	257	6,7	1,32	1,17	227	5,3	1,01	1,01	173	4,3	0,76	0,76	130	1,9
	2 MED	270	1,28	1,02	220	5,1	1,12	0,97	193	4,0	0,86	0,86	147	3,2	0,64	0,64	109	1,4
1 MIN	205	1,05	0,82	181	3,6	0,92	0,77	159	2,8	0,70	0,70	120	2,2	0,51	0,51	89	1,0	
WFS 2	6	545	2,00	1,73	345	11,4	1,78	1,68	306	9,2	1,39	1,39	238	7,7	1,17	1,17	201	4,2
	5 MAX	480	1,86	1,58	319	9,9	1,64	1,53	283	8,0	1,27	1,27	219	6,6	1,05	1,05	181	3,5
	4	400	1,66	1,38	286	8,1	1,47	1,33	253	6,5	1,13	1,13	194	5,3	0,88	0,88	152	2,5
	3 MED	365	1,56	1,29	269	7,3	1,38	1,24	238	5,8	1,06	1,06	182	4,7	0,81	0,81	139	2,2
	2	305	1,39	1,12	239	5,9	1,22	1,07	210	4,7	0,93	0,93	160	3,8	0,70	0,70	120	1,7
1 MIN	250	1,21	0,96	208	4,6	1,06	0,91	183	3,6	0,81	0,81	139	2,9	0,60	0,60	103	1,3	
WFS 3	6	780	3,23	2,66	556	29,5	2,87	2,57	493	23,7	2,22	2,22	382	17,8	1,69	1,69	290	9,0
	5	730	3,10	2,53	534	27,4	2,75	2,44	474	22,0	2,13	2,13	366	16,5	1,61	1,61	277	8,2
	4 MAX	545	2,58	2,04	444	19,7	2,28	1,95	392	15,7	1,74	1,74	300	11,5	1,31	1,31	225	5,6
	3	480	2,37	1,84	407	16,9	2,09	1,76	359	13,4	1,59	1,59	274	9,8	1,19	1,19	204	4,8
	2 MED	375	1,98	1,50	340	12,2	1,74	1,43	299	9,6	1,32	1,29	226	6,9	0,97	0,97	167	3,3
1 MIN	280	1,61	1,20	277	8,4	1,42	1,13	244	6,7	1,07	1,01	183	4,8	0,78	0,78	135	2,2	
WFS 4	6 MAX	790	3,26	2,68	560	29,9	2,89	2,59	497	24,0	2,24	2,24	385	18,1	1,70	1,70	293	9,1
	5	675	2,96	2,39	509	25,1	2,62	2,30	450	20,1	2,02	2,02	347	15,0	1,52	1,52	262	7,5
	4 MED	610	2,78	2,22	478	22,5	2,46	2,13	423	18,0	1,89	1,89	325	13,3	1,42	1,42	244	6,6
	3	500	2,44	1,90	419	17,7	2,15	1,82	370	14,1	1,64	1,64	282	10,3	1,22	1,22	211	5,0
	2 MIN	440	2,23	1,72	384	15,2	1,97	1,64	338	12,0	1,49	1,49	257	8,7	1,11	1,11	191	4,2
1	300	1,70	1,27	292	9,3	1,49	1,20	257	7,3	1,12	1,07	193	5,2	0,83	0,83	142	2,5	

Entering air temperature: +27°C - Relative Humidity: 50%

Model	Vdc	WT: 7/12 °C					WT: 8/13 °C				WT: 10/15 °C				WT: 12/17 °C			
		Qv m³/h	Pc kW	Ps kW	Qw l/h	Dp(c) kPa	Pc kW	Ps kW	Qw l/h	Dp(c) kPa	Pc kW	Ps kW	Qw l/h	Dp(c) kPa	Pc kW	Ps kW	Qw l/h	Dp(c) kPa
WFS-ECM 1	10 MAX	415	2,15	1,55	370	12,9	1,93	1,47	331	10,5	1,51	1,37	259	6,7	1,15	1,15	198	4,1
	7,5	355	1,95	1,38	335	10,8	1,75	1,31	300	8,8	1,36	1,21	234	5,6	1,04	1,04	178	3,4
	5 MED	290	1,70	1,19	293	8,5	1,53	1,12	263	7,0	1,19	1,03	204	4,4	0,90	0,90	154	2,6
	3	240	1,49	1,03	257	6,7	1,34	0,97	231	5,5	1,04	0,88	179	3,4	0,78	0,78	134	2,0
	1 MIN	190	1,26	0,86	217	4,9	1,14	0,81	196	4,1	0,88	0,73	151	2,5	0,66	0,66	113	1,5
WFS-ECM 2	10 MAX	510	2,43	1,78	418	16,1	2,18	1,71	375	13,2	1,71	1,61	295	8,5	1,32	1,32	227	5,3
	7,5	440	2,23	1,61	383	13,8	2,00	1,53	343	11,2	1,57	1,44	269	7,2	1,20	1,20	206	4,4
	5 MED	375	2,02	1,44	347	11,5	1,81	1,36	311	9,4	1,41	1,27	243	6,0	1,08	1,08	185	3,6
	3	315	1,80	1,27	309	9,4	1,61	1,20	278	7,7	1,26	1,10	216	4,8	0,95	0,95	164	2,9
	1 MIN	260	1,58	1,10	271	7,4	1,42	1,03	244	6,1	1,10	0,94	189	3,8	0,83	0,83	142	2,3
WFS-ECM 3	10 MAX	620	3,53	2,48	607	34,6	3,18	2,34	547	28,6	2,49	2,16	428	18,2	1,90	1,90	327	11,1
	7,5	520	3,14	2,18	541	28,1	2,84	2,05	489	23,3	2,22	1,88	381	14,8	1,68	1,68	289	8,9
	5 MED	420	2,71	1,85	467	21,5	2,45	1,75	422	17,9	1,91	1,58	329	11,3	1,44	1,44	247	6,7
	3	345	2,36	1,59	405	16,7	2,14	1,50	367	13,9	1,66	1,34	286	8,8	1,24	1,22	214	5,2
	1 MIN	270	1,96	1,31	338	12,0	1,78	1,23	307	10,1	1,39	1,10	239	6,4	1,03	0,98	178	3,7
WFS-ECM 4	10 MAX	770	4,03	2,88	693	44,0	3,63	2,73	624	36,2	2,86	2,56	491	23,3	2,20	2,20	378	14,4
	7,5	665	3,69	2,60	634	37,5	3,32	2,46	571	30,9	2,61	2,28	448	19,8	1,99	1,99	343	12,1
	5 MED	550	3,26	2,27	562	30,1	2,95	2,14	507	24,9	2,30	1,96	396	15,8	1,75	1,75	301	9,6
	3	465	2,91	2,00	501	24,5	2,63	1,89	453	20,3	2,05	1,72	353	12,8	1,55	1,55	267	7,7
	1 MIN	375	2,50	1,70	431	18,7	2,27	1,60	390	15,5	1,76	1,44	303	9,8	1,32	1,31	228	5,8

Entering air temperature: +26°C - Relative Humidity: 50%

Model	Vdc	WT: 7/12 °C					WT: 8/13 °C				WT: 10/15 °C				WT: 12/17 °C			
		Qv m³/h	Pc kW	Ps kW	Qw l/h	Dp(c) kPa	Pc kW	Ps kW	Qw l/h	Dp(c) kPa	Pc kW	Ps kW	Qw l/h	Dp(c) kPa	Pc kW	Ps kW	Qw l/h	Dp(c) kPa
WFS-ECM 1	10 MAX	415	1,92	1,47	330	10,5	1,70	1,42	293	8,5	1,32	1,32	227	5,3	1,01	1,01	173	3,2
	7,5	355	1,74	1,31	299	8,8	1,54	1,26	265	7,1	1,19	1,17	205	4,4	0,90	0,90	155	2,6
	5 MED	290	1,52	1,13	261	6,9	1,35	1,08	232	5,5	1,03	0,99	178	3,4	0,78	0,78	134	2,0
	3	240	1,33	0,97	230	5,5	1,18	0,93	203	4,4	0,90	0,84	155	2,7	0,67	0,67	116	1,6
	1 MIN	190	1,13	0,81	194	4,1	1,00	0,77	172	3,2	0,76	0,69	131	2,0	0,56	0,56	97	1,1
WFS-ECM 2	10 MAX	510	2,17	1,71	373	13,1	1,93	1,66	333	10,6	1,51	1,51	260	6,7	1,16	1,16	199	4,1
	7,5	440	1,99	1,53	342	11,2	1,77	1,48	304	9,0	1,37	1,37	236	5,7	1,05	1,05	180	3,5
	5 MED	375	1,80	1,37	310	9,4	1,60	1,31	275	7,5	1,24	1,22	213	4,7	0,94	0,94	161	2,8
	3	315	1,61	1,20	276	7,6	1,42	1,15	245	6,1	1,10	1,06	188	3,8	0,83	0,83	142	2,3
	1 MIN	260	1,41	1,04	243	6,1	1,25	0,99	215	4,8	0,96	0,90	165	3,0	0,72	0,72	123	1,7
WFS-ECM 3	10 MAX	620	3,17	2,34	545	28,5	3,29	2,50	565	30,4	2,18	2,07	375	14,4	1,85	1,85	318	26,6
	7,5	520	2,82	2,06	486	23,2	2,93	2,19	504	24,8	1,93	1,80	333	11,6	1,64	1,64	282	21,4
	5 MED	420	2,44	1,75	420	17,8	2,53	1,86	436	19,0	1,66	1,50	286	8,8	1,41	1,41	242	16,2
	3	345	2,12	1,50	365	13,8	2,20	1,60	379	14,8	1,44	1,28	248	6,8	1,22	1,20	209	12,5
	1 MIN	270	1,77	1,24	304	10,0	1,83	1,31	316	10,7	1,20	1,04	207	4,9	1,01	0,97	174	9,0
10 MAX	770	3,61	2,73	621	36,0	3,22	2,64	554	29,2	2,51	2,46	432	18,5	1,92	1,92	330	11,3	



<b>WFS-ECM 4</b>	7,5		665	3,30	2,46	568	30,7	2,94	2,37	506	24,8	2,28	2,19	393	15,6	1,73	1,73	298	9,4
	5	MED	550	2,93	2,15	504	24,8	2,61	2,05	449	20,0	2,01	1,88	346	12,4	1,52	1,52	261	7,4
	3		465	2,62	1,89	450	20,2	2,33	1,80	400	16,3	1,79	1,64	308	10,0	1,34	1,34	231	5,9
	1	MIN	375	2,25	1,61	387	15,4	2,00	1,52	345	12,4	1,53	1,37	264	7,6	1,14	1,14	196	4,4

Entering air temperature: +25°C - Relative Humidity: 50%

Model	Vdc	WT: 7/12 °C					WT: 8/13 °C					WT: 10/15 °C					WT: 12/17 °C				
		Qv	Pc	Ps	Qw	Dp(c)	Pc	Ps	Qw	Dp(c)	Pc	Ps	Qw	Dp(c)	Pc	Ps	Qw	Dp(c)			
		m³/h	kW	kW	l/h	kPa	kW	kW	l/h	kPa	kW	kW	l/h	kPa	kW	kW	l/h	kPa			
<b>WFS-ECM 1</b>	10	MAX	415	1,70	1,42	292	8,5	1,50	1,37	258	6,7	1,16	1,16	199	4,2	0,91	0,91	157	2,7		
	7,5		355	1,54	1,26	264	7,1	1,36	1,21	233	5,6	1,04	1,04	179	3,4	0,79	0,79	135	2,1		
	5	MED	290	1,34	1,08	231	5,5	1,18	1,03	203	4,4	0,90	0,90	155	2,7	0,67	0,67	116	1,6		
	3		240	1,18	0,93	202	4,4	1,03	0,88	178	3,4	0,78	0,78	135	2,1	0,58	0,58	100	1,2		
1	MIN	190	1,00	0,77	171	3,2	0,87	0,73	150	2,5	0,66	0,66	113	1,5	0,49	0,49	83	0,9			
<b>WFS-ECM 2</b>	10	MAX	510	1,93	1,65	331	10,6	1,71	1,60	294	8,5	1,33	1,33	228	5,3	1,11	1,11	191	3,9		
	7,5		440	1,76	1,48	303	9,0	1,56	1,43	268	7,2	1,20	1,20	207	4,5	0,97	0,97	166	3,0		
	5	MED	375	1,59	1,31	274	7,5	1,41	1,26	242	6,0	1,08	1,08	186	3,7	0,83	0,83	143	2,3		
	3		315	1,42	1,15	244	6,1	1,25	1,10	215	4,9	0,95	0,95	164	3,0	0,72	0,72	123	1,7		
1	MIN	260	1,24	0,99	214	4,8	1,10	0,94	188	3,8	0,83	0,83	143	2,3	0,62	0,62	106	1,3			
<b>WFS-ECM 3</b>	10	MAX	620	2,81	2,25	483	22,9	2,48	2,15	427	18,3	1,91	1,91	328	11,3	1,44	1,44	247	6,7		
	7,5		520	2,50	1,96	430	18,6	2,21	1,88	380	14,8	1,69	1,69	290	9,0	1,26	1,26	217	5,3		
	5	MED	420	2,16	1,66	371	14,3	1,90	1,58	328	11,3	1,44	1,43	248	6,8	1,07	1,07	185	4,0		
	3		345	1,88	1,42	323	11,1	1,65	1,35	284	8,8	1,25	1,21	215	5,3	0,92	0,92	159	3,0		
1	MIN	270	1,57	1,17	270	8,1	1,38	1,10	237	6,4	1,04	0,98	178	3,8	0,76	0,76	131	2,1			
<b>WFS-ECM 4</b>	10	MAX	770	3,21	2,63	551	29,1	2,85	2,54	490	23,4	2,20	2,20	379	14,6	1,67	1,67	288	8,8		
	7,5		665	2,93	2,37	504	24,8	2,59	2,27	446	19,8	2,00	2,00	344	12,3	1,51	1,51	259	7,3		
	5	MED	550	2,60	2,05	447	19,9	2,29	1,96	395	15,9	1,76	1,76	302	9,7	1,32	1,32	226	5,7		
	3		465	2,32	1,80	399	16,2	2,04	1,71	351	12,9	1,56	1,56	268	7,8	1,16	1,16	199	4,6		
1	MIN	375	2,00	1,52	343	12,4	1,76	1,44	302	9,8	1,33	1,30	229	5,9	0,98	0,98	169	3,4			

- WT = Water temperature
- PC = Total cooling capacity
- PS = Sensible cooling capacity
- QW = Water flow
- Dpc = Water side pressure drop
- QV = Air flow



# Performance data - Heating

The following standard rating conditions are used:

COOLING (summer operation)

Entering air temperature: + 27°C d.b. / + 19°C w.b. - Water temperature: + 7°C E.W.T. / + 12°C L.W.T.

HEATING (winter operation)

Entering air temperature: + 20°C Water temperature: + 50°C E.W.T.

Water flow rate as for the cooling conditions

## Entering air temperature: +20°C

Model	Fan Speed	WT: 70/60 °C				WT: 60/50 °C			WT: 50/40 °C			WT: 50/45 °C			WT: 45/40 °C			
		Qv m³/h	Ph kW	Qw l/h	Dp(c) kPa	Ph kW	Qw l/h	Dp(c) kPa	Ph kW	Qw l/h	Dp(c) kPa	Ph kW	Qw l/h	Dp(c) kPa	Ph kW	Qw l/h	Dp(c) kPa	
WFS 1	6	500	5,46	470	15,0	4,22	363	9,7	2,96	254	5,3	3,32	571	22,6	2,71	466	15,9	
	5	470	5,22	449	13,8	4,03	346	9,0	2,83	244	4,9	3,17	545	20,8	2,58	444	14,7	
	4	MAX	375	4,40	378	10,1	3,40	293	6,6	2,40	206	3,6	2,67	459	15,3	2,18	375	10,8
	3		340	4,07	350	8,8	3,16	271	5,8	2,23	191	3,2	2,48	427	13,3	2,02	347	9,4
	2	MED	270	3,39	292	6,4	2,63	226	4,2	1,86	160	2,3	2,06	354	9,6	1,68	289	6,8
	1	MIN	205	2,71	233	4,2	2,11	181	2,8	1,50	129	1,6	1,64	282	6,4	1,34	230	4,5
WFS 2	6	545	5,82	514	16,8	4,49	397	10,9	3,15	278	6,0	3,54	609	25,4	2,88	495	17,8	
	5	MAX	480	5,30	468	14,2	4,09	361	9,2	2,87	254	5,0	3,22	554	21,4	2,62	451	15,1
	4		400	4,62	408	11,1	3,57	315	7,2	2,52	222	4,0	2,81	483	16,7	2,29	394	11,8
	3	MED	365	4,31	380	9,8	3,33	294	6,4	2,35	207	3,5	2,62	451	14,7	2,13	366	10,4
	2		305	3,74	329	7,6	2,90	255	4,9	2,05	180	2,7	2,27	390	11,4	1,85	318	8,1
	1	MIN	250	3,19	280	5,7	2,47	218	3,7	1,75	155	2,1	1,93	332	8,5	1,58	272	6,1
WFS 3	6	780	8,54	754	36,7	6,61	585	24,0	4,68	414	13,4	5,19	893	55,5	4,24	729	39,2	
	5		730	8,13	717	33,6	6,31	556	22,0	4,46	394	12,3	4,94	850	50,8	4,04	695	35,9
	4	MAX	545	6,51	573	22,5	5,06	446	14,8	3,59	317	8,3	3,95	679	34,0	3,23	556	24,1
	3		480	5,89	518	18,8	4,58	403	12,4	3,26	288	7,0	3,57	614	28,4	2,93	504	20,1
	2	MED	375	4,78	420	12,9	3,72	327	8,5	2,66	234	4,8	2,90	499	19,4	2,37	408	13,8
	1	MIN	280	3,79	332	8,5	2,96	260	5,7	2,13	187	3,2	2,30	396	12,8	1,89	325	9,1
WFS 4	6	MAX	790	8,62	761	37,4	6,68	590	24,4	4,72	418	13,6	5,24	901	56,5	4,28	736	39,9
	5		675	7,66	676	30,2	5,95	525	19,8	4,21	373	11,0	4,66	802	45,7	3,80	654	32,3
	4	MED	610	7,11	627	26,4	5,52	487	17,3	3,92	346	9,7	4,32	743	39,8	3,53	607	28,2
	3		500	6,08	535	19,9	4,73	417	13,1	3,37	297	7,4	3,69	635	30,0	3,02	519	21,3
	2	MIN	440	5,49	483	16,6	4,28	376	10,9	3,05	269	6,2	3,34	574	25,0	2,73	470	17,8
	1		300	4,02	352	9,5	3,14	275	6,3	2,25	198	3,6	2,43	418	14,2	2,00	344	10,1

## Entering air temperature: +20°C

Model	Vdc	WT: 70/60 °C				WT: 60/50 °C			WT: 50/40 °C			WT: 50/45 °C			WT: 45/40 °C			
		Qv m³/h	Ph kW	Qw l/h	Dp(c) kPa	Ph kW	Qw l/h	Dp(c) kPa	Ph kW	Qw l/h	Dp(c) kPa	Ph kW	Qw l/h	Dp(c) kPa	Ph kW	Qw l/h	Dp(c) kPa	
WFS-ECM 1	10	MAX	415	4,75	409	11,7	3,67	316	7,6	2,58	222	4,2	2,89	497	17,6	2,35	405	12,4
	7,5		355	4,22	363	9,4	3,26	281	6,1	2,30	198	3,4	2,56	441	14,2	2,09	359	10,0
	5	MED	290	3,59	309	7,0	2,79	240	4,6	1,97	169	2,6	2,18	375	10,6	1,78	306	7,5
	3		240	3,08	265	5,3	2,39	206	3,5	1,70	146	2,0	1,87	322	8,1	1,53	263	5,7
	1	MIN	190	2,54	219	3,8	1,98	170	2,5	1,41	121	1,4	1,54	265	5,7	1,26	217	4,0
WFS-ECM 2	10	MAX	510	5,55	477	15,4	4,28	368	10,0	3,00	258	5,5	3,37	580	23,3	2,74	472	16,3
	7,5		440	4,97	427	12,6	3,83	330	8,2	2,70	232	4,5	3,02	519	19,1	2,46	423	13,4
	5	MED	375	4,40	378	10,1	3,40	293	6,6	2,40	206	3,6	2,67	460	15,3	2,18	375	10,8
	3		315	3,84	330	7,9	2,97	256	5,2	2,10	181	2,9	2,33	401	12,0	1,90	327	8,4
	1	MIN	260	3,29	283	6,0	2,55	220	3,9	1,81	156	2,2	2,00	344	9,1	1,63	281	6,4
WFS-ECM 3	10	MAX	620	7,19	618	26,9	5,58	480	17,7	3,96	340	9,9	4,36	751	40,6	3,57	614	28,8
	7,5		520	6,27	539	21,1	4,87	419	13,8	3,47	298	7,8	3,81	655	31,8	3,11	536	22,5
	5	MED	420	5,29	455	15,5	4,12	354	10,2	2,94	253	5,8	3,21	553	23,4	2,63	452	16,6
	3		345	4,51	388	11,6	3,52	303	7,7	2,52	216	4,4	2,74	471	17,5	2,24	386	12,5
	1	MIN	270	3,68	316	8,1	2,87	247	5,4	2,06	177	3,1	2,23	383	12,1	1,83	315	8,7
WFS-ECM 4	10	MAX	770	8,45	727	36,1	6,55	564	23,6	4,64	399	13,1	5,14	884	54,5	4,20	722	38,6
	7,5		665	7,58	652	29,6	5,88	506	19,4	4,17	359	10,8	4,61	792	44,7	3,76	647	31,7
	5	MED	550	6,55	563	22,8	5,09	438	15,0	3,62	311	8,4	3,98	685	34,4	3,26	560	24,4
	3		465	5,74	494	18,0	4,47	384	11,8	3,18	274	6,7	3,49	600	27,1	2,85	491	19,3
	1	MIN	375	4,83	415	13,2	3,76	324	8,7	2,69	231	4,9	2,93	504	19,8	2,40	413	14,1



## Electric heater

According to the control provided, the electric heater can be used as an alternative or as a supplement to the hot water; in the first case, controls such as T-TMO can be chosen. In the second case, controls such as T-REM can be chosen.

The heater is hermetically sealed and supplied inside the coil pipes and therefore can only be factory-mounted. The electric heaters of the WFS/WFE units are single-phase 230V supply.

The electric heater is fitted with an overheat protection. The unit is fitted with two safety thermostats:

- one thermostat with manual reset
- one thermostat with automatic reset.

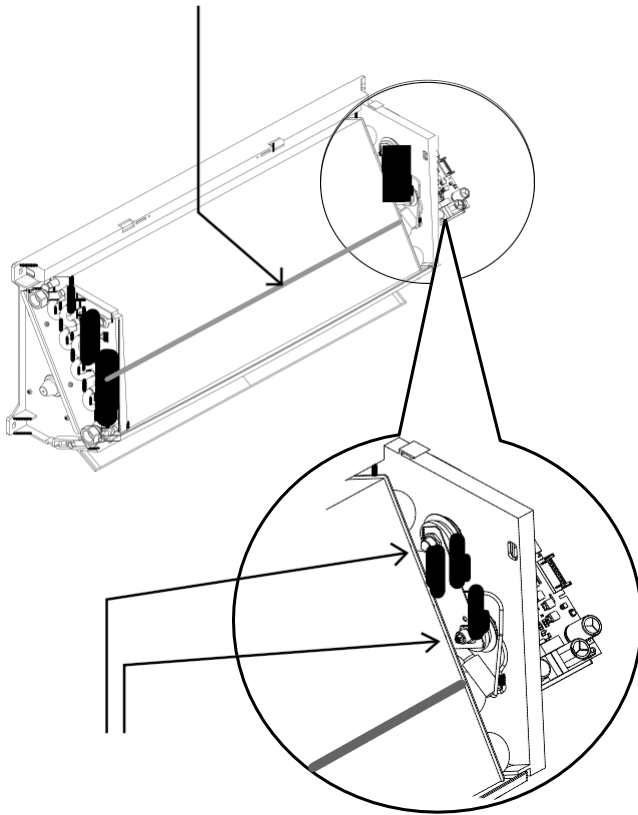

### Electric heater characteristics

Model	WFS 1	WFS 2	WFS 3	WFS 4
Nominal installed power	1000 Watt	1000 Watt	1500 Watt	1500 Watt
Nominal power voltage	230V ~	230V ~	230V ~	230V ~
Number and section of connecting wires	3 x 1,5mm <sup>2</sup>	3 x 1,5mm <sup>2</sup>	3 x 1,5mm <sup>2</sup>	3 x 1,5mm <sup>2</sup>
Current input	4,5 A	4,5 A	7 A	7 A
Recommended fuse (Type gG) for overload protection	6 A	6 A	8 A	8 A

## WFS/WFE operating limits with electric heater

Max. ambient temperature for WFS/WFE with electric coil in heating mode: 25°C

### Coil pressure drop

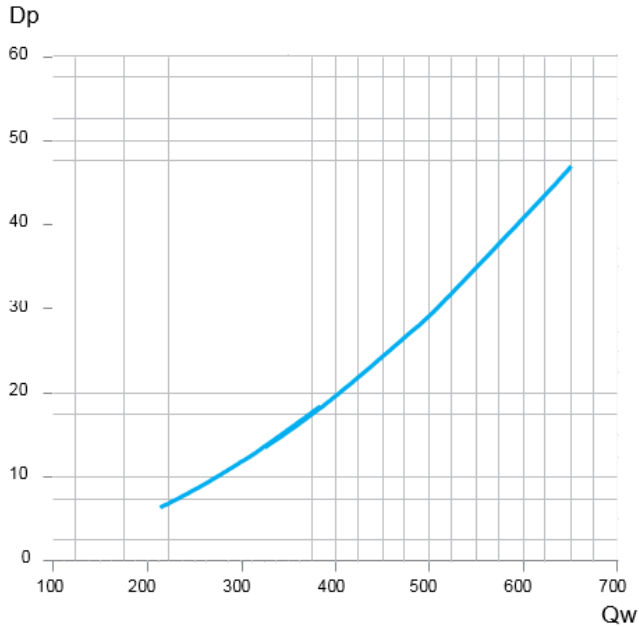

Pressure drop for mean water temperature of 10°C. For different temperatures, multiply the pressure drop figure by the K correction factors in the table.

°C	20	30	40	50	60	70	80
K	0,94	0,90	0,86	0,82	0,78	0,74	0,70

### Valves pressure drop

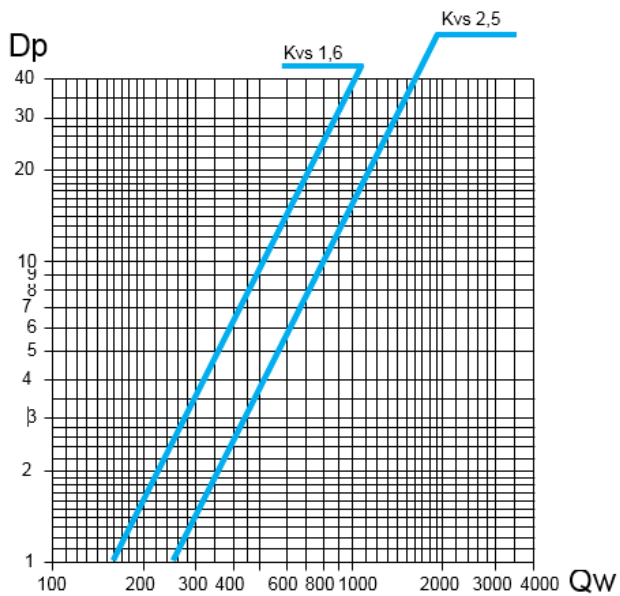

**Qw** = water flow (l/h)

**Dp** = pressure drop (kPa)

# Accessories

## FV3S – 3-way valve

Model	Valve			Code
	DN	(Ø)	Kvs	Not Fitted
1 - 2	15	1/2"	1,6	9025321H
3 - 4	20	3/4"	2,5	9025323H

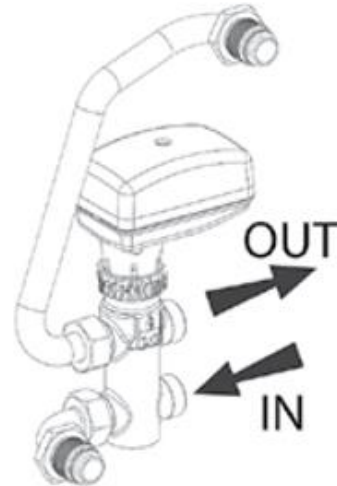

## FV2S – 2-way valve

Model.	Valve			Code
	DN	(Ø)	Kvs	Not Fitted
1 - 2	15	1/2"	1,6	9025311H
3 - 4	20	3/4"	2,5	9025313H

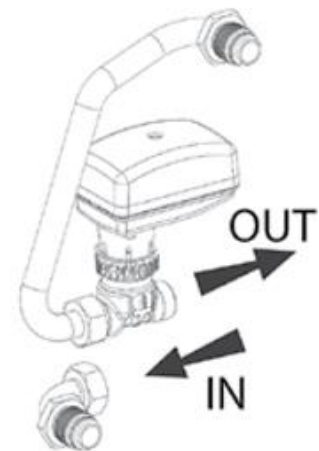

## PCF condensate drain pump

	Fitted	Not Fitted
ID	PCF-M	PCF-S
Code	9025319	9025309

Height for vertical flow	Water flow (l/h) depending on the length of horizontal flow	
	5m	10 m
1	7,6	7,2
2	5,6	5,2
3	4,0	3,7
4	3,2	2,9



## WFE configuration

For this fan coil configuration, the 1-10 Vdc signal, which controls the inverter, must be supplied by a controller with the following signal specifications:

- Impedance < 100 Ohm
- Maximum speed: 10 Vdc
- Fan off with V: < 1 vdc
- Signal 1-10 Vdc



## Controls overview

	WM-3V	T-TMO	T-REM	TB-503	M-2T
	9066642	9066630T	9066631T	9060173	9060174
ON-OFF switch	X	X	X	X	X
ON-OFF electric heater			X		
Manual 3 speed switch	X	X	X	X	X
Manual/Automatic 3 speed selection		X	X	X	X
Summer/Winter switch			X		
Remote centralized Summer/Winter switch or by an automatic change-over fitted on the water pipe		X	X	X	X
Room thermostat for fan control (ON-OFF)		X	X	X	X
Room thermostat for 1 valve control		X	X	X	X
Simultaneous thermostatic control of the valves and fan		X	X	X	
Room thermostat for chilled water valve (SUMMER) and electric heater (WINTER) control (in winter only the heater is working)		X	X	X	
Installation of electronic low temperature CUT-OUT thermostat (LTCO)			X	X	
Installation of bimetallic low temperature CUT-OUT thermostat (TMM)		X			

### WM-3V (9066642)



- Manual 3 speed switch.
- Without thermostatic control.
- It can not control the valves.

**Dimensions: 75x75x30 mm**

### T-REM (9066631T)



- ON-OFF switch.
- Manual 3 speed switch.
- Manual Summer/Winter switch.
- Electric heater activation button.
- Electronic room thermostat for fan control (ON-OFF).
- Electronic room thermostat for valve control (ON-OFF).
- Simultaneous thermostatic control of the valves and fan.
- It allows to control the low temperature cut-out thermostat (LTCO).
- It allows to control the water valves (ON-OFF) and the electric heater managed as main heating element or as an integration element.
- It allows to control the summer/winter cycle with a centralized and remote switch or with an automatic change-over fitted on the water pipe (for 2-tube installations only).
- Energy saving function.

**Dimensions: 135x86x31 mm**



### T-TMO (9066630T)



- ON-OFF switch.
- Manual 3 speed switch.
- Manual Summer/Winter switch.
- Electronic room thermostat for fan control (ON-OFF).
- Electronic room thermostat for valve control (ON-OFF) (the fan keeps working).
- It allows to control the low temperature cut-out thermostat (TMM).
- It allows to control the chilled water valve (ON-OFF) and the electric heater (BEL).

**Dimensions: 135x86x31 mm**

### TB-503 (9060172)



The TMO-503-SV2 control for fan coils with valves, is designed to be installed in a 503 wall box. The control is supplied integral with the external frame, but it is possible to use frames of the most known brand on the market (BTicino, Vimar, AVE, Gewiss).

- Manual or automatic speed switch.
- Manual Summer/Winter switch.
- Electronic thermostat for valve(s) control (ON-OFF).
- Simultaneous thermostatic control on the valves and fan (ON-OFF).
- It allows to control the low temperature cut-out thermostat (included with the control).

**Dimensions: 118x87x8 mm**

### M-2T (9060174)



- ON-OFF switch.
- 3 speed switch.
- Manual Summer/Winter switch.
- Electronic thermostat for fan control.
- Thermostatic control on the valve and continuous fan operation.
- Simultaneous thermostatic control on the valves and fan.
- Cannot be used with SEL-CVP speed switch (master-slave).

**Dimensions: 128x75x25 mm**

# Controls accessories

## REL-3 (9025302)



- Speed switch (slave).
- It allows to control up to 8 units with only one centralized thermostat using one speed switch for each unit.
- For controls: T-TMO, T-REM and TMO-503-SV2.

## LTCO (9053048) : LTCO low temperature cut-out thermostat



To be fitted between the coil fins.  
 When connecting the control, the LTCO probe cable must be separated from the power supply wires. To be used with the following controls: T-REM.  
 It stops the fan when the water temperature is lower than 28°C and it starts the fan when is higher than 33°C.

## TMM (9053048) – TMM low temperature cut-out thermostat

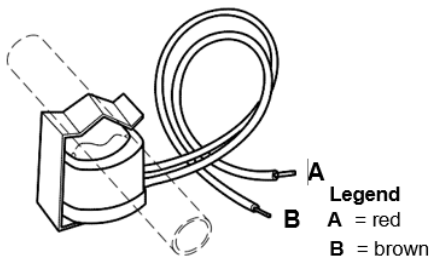

To be installed in contact with the hot water circuit. To be used with the following controls only: T-TMO. For units working on heating only.  
 It stops the fan when the water temperature is lower than 30°C and it starts the fan when is higher than 38°C.

## CH 15-25 (9053049) – CH 15-25 change-over

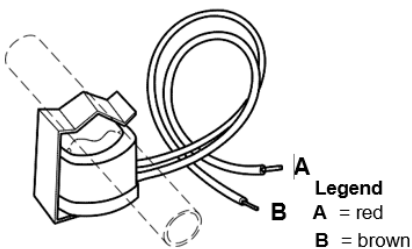

Automatic summer/winter switch to be installed in contact with the water circuit.  
 Not to be used with 2 way valve.  
 To be used with the following controls only: T-REM.



## IR and MB versions

All the **WFS/WFE** units can be supplied in **IR version** and in **MB version**.

- The **IR version** includes the infra-red remote control that allows the management of a single unit (the units can not be controlled in a network).
- The **MB version** includes a wide range of controls, including the **infra-red remote control** (optional extra), which allows to manage one single unit or several units by using the Modbus RTU - RS 485 communication protocol. Units can be managed according to the Master/Slave logic (up to 20 units) or by supervisory controls.

The system consists in a **MB** power board (mounted on models WFS-MB) and a series of controls, such as the **IR-MB** wall mounted control, the **RT03** infra-red remote control, and the **TODS** multifunction control.

### IR-MB wall control (9066331E)



Wall control with display that allows controlling one or more units in Master/Slave mode. The control is equipped with internal sensor to detect the room temperature, which can be defined as a priority compared to the return air sensor on the fan coil.

The **IR-MB** control features the following functions:

- Switch the appliance ON and OFF.
- Temperature set.
- Modify the set point (when used as a +/- 3° variation of the set point configured from BMS or TODS).
- Set the fan speed (low, medium, high or autofan).
- Set the operation mode (fan only, cooling, heating).
- Time setting.
- Weekly ON/OFF program.
- Display and change of the fan coil operation parameters.

**Dimensions : 110x72x25 mm**

### RT-03 infrared remote control

The infra-red remote control allows setting by a remote position the fan coil operation parameters.

The RT03 infra-red remote control features the following functions:

- Switch the appliance ON and OFF.
- Temperature set.
- Set the fan speed (low, medium, high or autofan).
- Set the operation mode (fan only, cooling, heating).
- Time setting.
- 24 hours ON/OFF program.

Description	Reference	Code
RT03 infra-red remote control with receiver supplied with separate packaging (to be used with MB board only)	RS-RT03-F	9025301
RT03 infra-red remote control with receiver supplied with separate packaging (to be used with MB board only)	RT03	3021203
Receiver for RT03 infra-red remote control supplied with separate packaging (to be used with MB board only)	RS-F	9025300

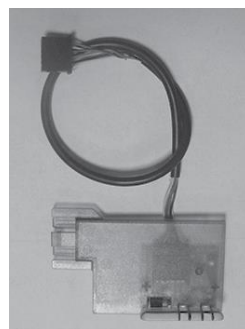
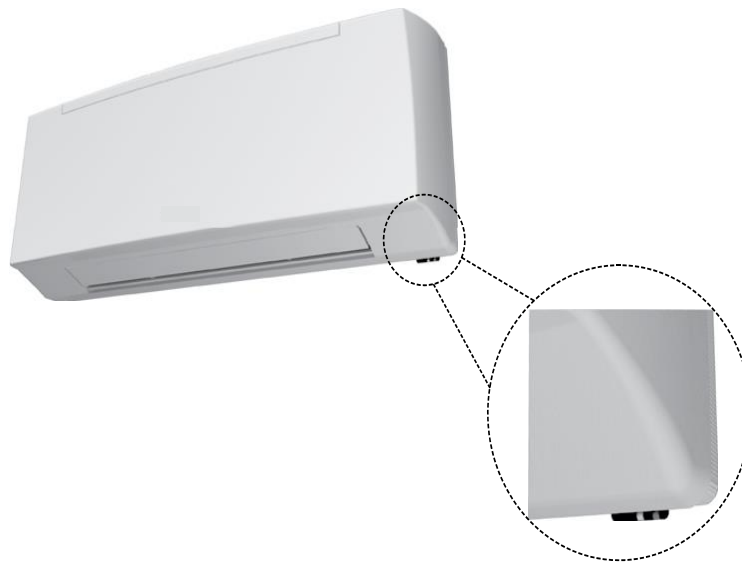



## MB Electronic board

The electronic board, mounted as per standard on the WFS-IR and WFE-IR, is set to carry out different functions and adjustment modes, in order to meet the installation requirements. These modes are selected by setting the configuration dip switches on the board.

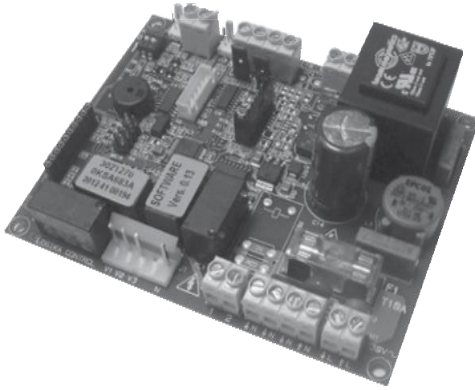

- Fan ON/OFF thermostatic control.
- Valve ON/OFF thermostatic control and continuous ventilation.
- Valve and simultaneous ventilation ON/OFF thermostatic control.
- Fan operation control depending on the coil temperature (cut-out T3 probe fitted), which can be activated only in heating mode or heating and cooling mode.
- Automatic switch of the operating mode by means of T2 water probe (optional).
- Seasonal switch by means of remote contact.
- ON/OFF of the fan coil by means of the remote contact (window or clock contact).
- Electric heater control

By activating the cut-out T3 probe function, the fan is stopped in winter when the coil temperature is lower than 32°C and started when the temperature reaches 36°C. In summer mode, the fan stops when the temperature inside the coil exceeds 22°C and starts when it drops below 18°C.

The infra-red remote control allows setting by a remote position the fan coil operation parameters. The RT03 infra-red remote control features the following functions:

- Switch the appliance ON and OFF.
- Temperature set.
- Set the fan speed (low, medium, high or autofan).
- Set the operation mode (fan only, cooling, heating).
- Time setting.
- 24 hours ON/OFF program.

A group of **WFS** units with **MB** electronic board can be connected via a serial link and can consequently be managed at the same time by just one **RMB** wall control or **RT03** infra-red remote control. Using the special jumper present on the MB board, one unit must be configured as the master, and all the others as slaves. The remote control must be pointed at the receiver on the master unit. To avoid problems, it is recommended to install and connect the receiver only on the master unit.

## With IR-MB wall control

**One control for each unit**  
 (maximum length of the connection cable = 20 m)



**One control for more units (20 units max.)**  
 (maximum total length of the connection cable = 800 m)

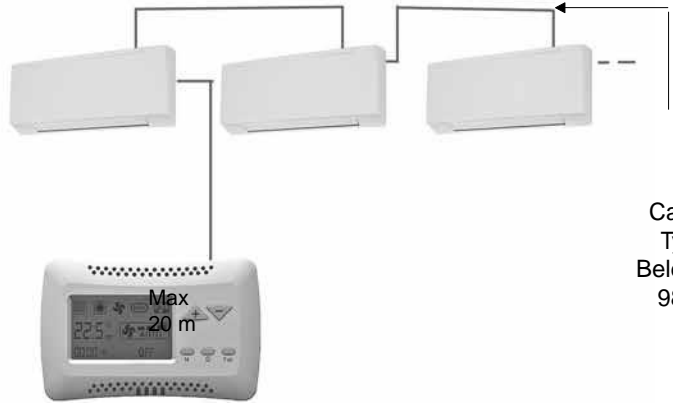

Cable Type  
 Belden  
 9841

## With RT03 infra-red remote control

**One control for each unit**



**One control for more units (20 units max.)**  
 (maximum total length of the connection cable = 800 m)

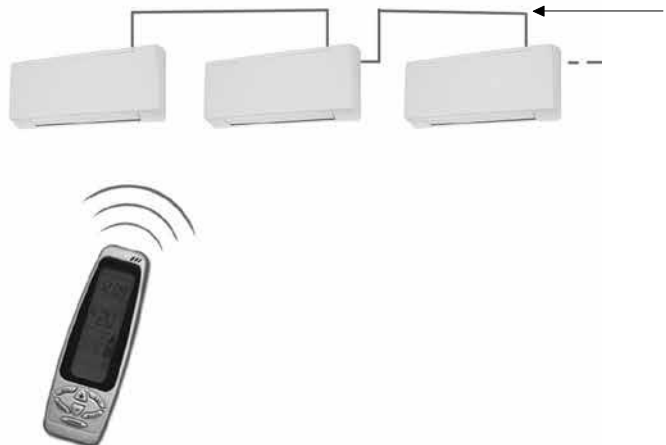

## Controls Accessories

### T2 (9025310) accessory for units with infra-red remote control and/or MB electronic board



**T2** sensor to be placed on the water supply pipe upstream 3 way valves (not to be used with 2 way valve). The **T2** sensor must be used as described below:

- Change-Over for the automatic switch of the operating mode. If water temperature is lower than 20°C, cooling mode is set; on the other hand, if water temperature exceeds 30°C, heating mode is set.
- It can be used on units with electric heater and hot water supply. The **T2** priority probe activates the electric heater or water valve, depending on the water temperature detected. If water temperature exceeds 34°C, the water valve ON-OFF control is activated; on the other hand, if water temperature is lower than 30°C, the electric heater is activated.

### TODS (3021293) Multifunction control panel

Another option available for the serial communication between the units is the possibility to connect up to 60 **WFS** units in series and manage them with just one wall mounted **TODS** controller.

The wall mounted controller can be used to set the operating mode for each individual unit connected, display the operating conditions of each individual unit, and set the ON/OFF time sets for each day of the week (the program can be set for all the units and for a maximum of two groups of units).

If more than 60 units need to be connected, two or more controllers must be used. Each unit must have a MB board.

The **TODS** control is used to manage a series of fan coils, up to a maximum of 60 units (the maximum length of the RS 485 connection cable must not exceed 800 m), from one single control point.

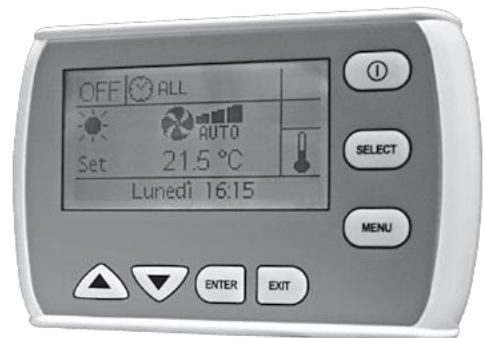

The **TODS** control communicates via a serial line with all the units connected, with the possibility of controlling them all together or individually. In fact, the unique address of each individual fan coil means that all the units can be called at the same time, or the individual unit called, to perform the following functions:

- display the current operating mode, the fan speed, the set point;
- display the room temperature measured on the individual unit;
- turn all the units ON and OFF at the same time or alternatively each unit individually;
- change the operating mode (fan only, heating, cooling, automatic changeover);
- change the set point;
- modify the values and operation parameters of the fan speed.



Each function can then be sent to all the units connected, or alternatively to each individual unit. Different set points or operating modes can be set for each individual unit.

The **TODS** panel can also be used for the time management of the units over the week. Four ON times and four OFF times can be set on the units for each day of the week. A different Temperature set that will be considered as Operation set for all connected appliances, can be set for each event. If the Temperature set is not entered for the individual event, it must be set during programming for each individual unit or for the entire network.

Units without receiver or with receiver can be connected within the network: the former can receive instructions only from the **TODS** wall mounted panel; while the latter can receive information from both the wall mounted panel (**TODS**) and infra-red remote control. Use the infra-red remote control to force ON mode of the individual unit, if ON/OFF daily time programming has been set. The unit will regain the settings from the **TODS** panel during execution of successive start-up program.

**Note:** set the configuration Dip Switches of each fan coil as illustrated in the remote control use manual, based on the required solutions.

**Note:** the RS 485 network's overall length must not exceed 700/800 metres.

## TODS Accessories

### SIOS board (302129)



SIOS is a board equipped with 8 relays with potential free contact to control the activation or deactivation of remote electric utilities. Moreover, the board has 8 digital inlets to display the actuators or external consents, such as motor or other. The SIOS boards can be connected to a TODS panel (one SIOS for each TODS panel).



Trane - by Trane Technologies (NYSE: TT), a global climate innovator - creates comfortable, energy efficient indoor environments for commercial and residential applications. For more information, please visit [trane.eu](http://trane.eu) or [tranetechnologies.com](http://tranetechnologies.com).

Trane has a policy of continuous product and product data improvement and reserves the right to change design and specifications without notice.

UNT-PRC023B-GB\_0221  
Supersedes UNT-PRC023AB-GB\_0617

©2020 Trane

Confidential and proprietary Trane information